

ICC-ES Evaluation Report

ESR-5231

Reissued March 2026



This report also contains:

[- CA Supplement with DSA & OSHPD](#)

Subject to renewal March 2027

ICC-ES Evaluation Reports are not to be construed as representing aesthetics or any other attributes not specifically addressed, nor are they to be construed as an endorsement of the subject of the report or a recommendation for its use. There is no warranty by ICC Evaluation Service, LLC, express or implied, as to any finding or other matter in this report, or as to any product covered by the report.

Copyright © 2026 ICC Evaluation Service, LLC. All rights reserved.

<p>DIVISION: 09 00 00— FINISHES</p> <p>Section: 09 24 00— Portland Cement Plastering</p>	<p>REPORT HOLDER:</p> <p>STUCCO SUPPLY CO. OF SAN JOSE</p> 	<p>EVALUATION SUBJECT:</p> <p>UNIWALL EXTERIOR WALL AND INSULATION STUCCO SYSTEM</p>	
--	--	--	---

1.0 EVALUATION SCOPE

Compliance with the following codes:

- 2024, 2021, 2018, 2015 and 2012 [International Building Code® \(IBC\)](#)
- 2024, 2021, 2018, 2015 and 2012 [International Residential Code® \(IRC\)](#)

Properties evaluated:

- Structural (Wind Resistance)
- Durability
- Fire-resistance-rated construction
- Types I, II, III or IV Construction
- Weather Protection

2.0 USES

Uniwall Exterior Wall and Insulation Stucco System are cementitious wall covering systems installed on exterior walls of wood-stud or steel-stud construction, concrete or concrete masonry construction. The systems are alternatives to the exterior wall coverings specified in IBC Chapter 25 and IRC Section R703. The systems are alternatives to three-coat exterior plaster in accordance with IBC Section 2512 and IRC Section R703.7. The systems are recognized for use in Types I, II, III, IV and V construction. When used on walls required to be in Type I, II, III or IV construction, installation must be as described in Section 4.5. When used to construct one-hour fire-resistance-rated wall assemblies, installation must be described in Section 4.4.

3.0 DESCRIPTION

3.1 General:

Uniwall Exterior Wall and Insulation Stucco Systems are a proprietary mixture of portland cement, sand, fibers, water and proprietary ingredients reinforced with wire fabric or metal lath and applied to substrates of expanded polystyrene (EPS), extruded polystyrene (XPS) and polyisocyanurate foam plastic insulation boards, concrete or concrete masonry, wood structural panels, fiberboard, or gypsum sheathing. The systems may be installed on exterior walls of wood-stud or steel-stud, concrete or concrete masonry construction.

3.2 Material:

3.2.1 Uniwall Concentrate: A factory-prepared mixture of Type I or II portland cement complying with ASTM C150, chopped Type E glass fibers or polypropylene fibers and proprietary additives. The mixture is packaged in 80-pound (36 kg) bags. Approximately 5 to 6 gallons (19 to 22.7 L) of water and 300 pounds (136 kg) of sand complying with Section 2.2.4 are added to each bag in the field and mixed in accordance with the manufacturer's recommendations.

3.2.2 Uniwall Sanded Exterior: A factory-prepared mixture of Type I or II portland cement complying with ASTM C150, sand complying with Section 3.2.4 and proprietary additives. The mixture is packaged in 80-pound (36 kg) bags. Approximately 2 gallons (7.6 L) of water are added to each bag in the field and mixed in accordance with manufacturer's recommendations.

3.2.3 Foam Tite Concentrate: A factory-prepared mixture of Type I or II portland cement complying with ASTM C150, chopped Type E glass fibers or polypropylene fibers and proprietary additives. The mixture is packaged in 80-pound (36 kg) bags. Approximately 5 to 6 gallons (19 to 22.7 L) of water and 200 pounds (88.6 kg) of sand complying with Section 3.2.4 are added to each bag in the field and mixed in accordance with the manufacturer's instructions.

3.2.4 Sand: Sand must be clean and free from deleterious amounts of loam, clay, silt, soluble salts and organic matter. Sampling and testing must comply with ASTM C144 or C897. Sand must be graded in accordance with ASTM C144 or C897 within the following limits:

RETAINED ON U.S. STANDARD SIEVE	PERCENT RETAINED BY WEIGHT ± 2 PERCENT	
	Natural Sand Min. / Max.	Manufactured Sand Min. / Max.
No. 4	0 / 0	0 / 0
No. 8	0 / 10	0 / 10
No. 16	10 / 40	10 / 40
No. 30	30 / 65	30 / 65
No. 50	70 / 90	60 / 80
No. 100	95 / 100	75 / 90

3.2.5 Fibers: Polypropylene fibers $\frac{1}{2}$ inch (12.7 mm) long, and chopped Type E glass fibers, $\frac{1}{4}$ to $\frac{1}{2}$ inch (6.4 to 12.7 mm) long, are used to prevent sagging of coating during application.

3.2.6 Admixture: Proprietary ingredients added to improve quality of the coating mixture.

3.2.7 Insulation Board:

3.2.7.1 Expanded Polystyrene Insulation Board:

The EPS insulation boards must have a minimum nominal density of 1.5 pounds per cubic foot, a 1-inch to 2-inch (25.4 mm to 50.8 mm) thickness, a flame-spread index of 25 or less and a smoke-developed index of 450 or less when tested in accordance with ASTM E84 or UL723 and must comply with ASTM C578 as Type II. All insulation boards must be recognized in a current ICC-ES evaluation report. See Section 7.3 for board identification.

Boards installed without sheathing, over open framing, must be provided with $\frac{3}{8}$ -inch-high (9.5 mm) tongues and compatible grooves for horizontal joints. See [Figure 2](#) for joint detail. Over solid substrates, square-edge foam plastic boards, complying with ASTM C578 as Type I, with a minimum $\frac{1}{2}$ -inch (12.7 mm) thickness and a minimum nominal density of 1 pcf (16 kg/m³) may be used, except when installation of the foam plastic board is as part of the water-resistive barrier over wood-based sheathing as described in Section 3.2.13.1, which requires 1-inch-thick (25.4 mm) EPS boards with tongue-and-groove edges.

When installation is over solid substrates, as described in Section 4.3, the boards must have minimum $\frac{1}{4}$ -inch-wide-by- $\frac{1}{8}$ -inch deep (6.4 mm by 3.2 mm) vertical grooves spaced at a maximum of 12 inches (305 mm) on the back face of the boards, as shown in [Figure 2](#). As an alternate to the vertical grooves in the foam plastic board, flat-faced boards may be installed over solid substrates provided the Tyvek StuccoWrap water-resistive barrier recognized in [ESR-2375](#) is installed behind the EPS boards.

As an alternative, Atlas ThermaStar[®] insulation boards, recognized in [ESR-1962](#) and having a minimum thickness of 1-inch (25.4 mm) and nominal density of 1.5 pounds per cubic foot (24 kg/m³), may also be used.

3.2.7.2 XPS Insulation Board:

XPS board must have a nominal density of 1.5 pounds per cubic foot (24 kg/m³), a 1-inch to 2-inch (25.4 mm to 50.8 mm) thickness, must comply with ASTM C578 as Type IV or V and must be recognized in a current ICC-ES evaluation report. See Section 3.2.7.1 for other details and requirements.

3.2.7.3 Polyisocyanurate Foam Plastic Board:

Polyisocyanurate foam plastic board must comply with ASTM C1289 as Type II. Polyisocyanurate foam plastic boards must have a nominal density of 2 pounds per cubic foot (32 kg/m³) and a maximum flame-spread index of 25 or less and a smoke-developed index of 450 or less when tested in accordance with ASTM E84 or UL723. Under the IRC, the polyisocyanurate foam plastic board may have a flame-spread index of 75 or less and a smoke-developed index of 450 or less. Under the IBC, the polyisocyanurate foam plastic board may have a flame-spread index of 75 or less and a smoke-developed index of 450 or less; except when installed in Type I, II, III or IV construction, the foam plastic board must have a flame-spread index of 25 or less and a smoke-developed index of 450 or less. The foam plastic board must be 1 inch to 1½ inches (25 to 38 mm) thick, have all squared joints installed at horizontal and vertical edges supported by framing or blocking. All boards must be recognized in a current ICC-ES evaluation report. See Section 7.3 for board identification requirements. Over solid substrates, a square-edge foam plastic board with a minimum thickness of ½ inch (12.7 mm) may be used, with the same requirements set forth in Section 3.2.7.1.

As an alternative, Atlas Roofing Energyshield® insulation boards, recognized in [ESR-1375](#) and having a 1-inch (25.4 mm) thickness and nominal density of 2.0 pounds per cubic foot (32 kg/m³), may also be used.

3.2.8 Lath:

3.2.8.1 Wire Fabric Lath:

Wire fabric lath must comply with the ICC-ES Acceptance Criteria for Metal Plaster Bases (Lath) (AC191). Minimum No. 20 gage [0.035 inch (0.89 mm)], 1-inch galvanized steel, woven-wire fabric must be used. Lath must be furred when applied over all substrates except unbacked polystyrene board. Furring must comply with the following requirements:

1. When maximum total coating thickness is ½ inch (12.7 mm) or less, the body of the lath must be furred a minimum of ⅛ inch (3.2 mm) from the substrate after installation.
2. When total coating thickness is greater than ½ inch (12.7 mm), No. 17 gage [0.058 inch (1.47 mm)] by 1½-inch (38 mm) woven-wire fabric lath must be used. The body of the lath must be furred a minimum of ¼ inch (6.4 mm) from the substrate after lath installation.

3.2.8.2 Metal Lath: Metal lath must comply with AC191. Furring requirements are as set forth in Section 3.2.8.1.

3.2.9 Gypsum Sheathing Board: Water-resistant core-treated gypsum sheathing must comply with ASTM C79 or ASTM C1396. Glass mat faced, water-resistant core-treated gypsum sheathing must comply with ASTM C1177 and be recognized in a current ICC-ES evaluation report. Water-resistant exterior fiber-reinforced gypsum sheathing must comply with ASTM C1278 and be recognized in a current ICC-ES evaluation report.

3.2.10 Fiberboard: Minimum ½-inch-thick (12.7 mm), asphalt-impregnated fiberboard must comply with ASTM C208 as Type IV, Grade 1 wall sheathing.

3.2.11 Wood Structural Panels: Wood structural panel sheathing must be minimum 5/16-inch-thick (7.9 mm) plywood or OSB with exterior glue for studs spaced 16 inches (406 mm) on center, and minimum 3/8-inch-thick (9.5 mm) plywood with exterior glue for studs spaced 24 inches (610 mm) on center. Plywood must be exterior-grade or Exposure 1 and comply with U.S. DOC PS-1; and OSB must be Exposure 1 and comply with U.S. DOC PS-2. Wood structural panels must comply with IBC Sections 2303.1.5, 2304.6.1 or IRC Section R602.3.

3.2.12 Caulking: Caulking materials must be either acrylic latex complying with ASTM C834, or polyurethane, polyurethane modified, polysulfide, or silyl-terminated polyether elastomeric sealant complying with ASTM C920.

3.2.13 Weather Protection:

3.2.13.1 Water-resistive Barrier: A water-resistive barrier is required and must comply with 2024, 2021 and 2018 IBC Section 1403.2 (2015 and 2012 IBC Section 1404.2) or IRC Section R703.2, as applicable. Minimum No. 15 asphalt nonperforated felt complying as Type I in accordance with ASTM D226 (IBC or IRC); or material recognized in a current ICC-ES evaluation report as equivalent to ASTM D226, Type I, is required.

When applied over any wood-based sheathing, the barrier must be either: (a) minimum of two layers of Grade D kraft building paper as set forth in 2024, 2021, 2018, 2015 and 2012 IBC Section 2510.6, or 2024, 2021, 2018 and 2015 IRC Section R703.7.3 or 2012 IRC Section R703.6.3, as applicable, or an equivalent recognized in a current ICC-ES evaluation report; or (b) one layer of EPS or XPS insulation board, having horizontal tongue-and-groove edges as described in Section 3.2.7.1, over one layer of Grade D kraft building paper having a minimum water-resistance rating of 60 minutes, or an equivalent recognized in a current ICC-ES evaluation report.

Fome-Cor Board, recognized as complying with ICC-ES AC38 and installed in accordance with evaluation report [ESR-1614](#), may be used as the water-resistive barrier.

When Tyvek StuccoWrap is used as the water-resistive barrier, it must be installed in accordance with [ESR-2375](#).

3.2.13.2 Vapor Retarder: Protection against condensation must be provided in accordance with 2024, 2021 and 2018 IBC Section 1404.3 (2015 and 2012 IBC Section 1405.3). Under the 2024, 2021, 2018, 2015 and 2012 IRC, a vapor retarder must be provided in accordance with IRC Section R702.7.

3.2.14 Flashing: Flashing complying with 2024, 2021 and 2018 IBC Section 1404.4 (2015 and 2012 IBC Section 1405.4), or 2024, 2021, 2018 and 2015 IRC Section R703.4 or 2012 IRC Section R703.8, must be provided. Where flexible flashing is used, it must be a self-adhering, flexible rubberized asphalt and polyethylene material, a minimum of 0.020 inch (0.51 mm) thick, shingle-lapped with the water-resistive barrier. Rigid flashings must be sloped towards the exterior, with an upturned leg on the interior side and at the ends and must extend beyond the surface of the exterior wall.

3.2.15 Trim and Accessories: All trim, weep screeds and corner reinforcement must be corrosion-resistant or approved plastic shall comply with IBC Section 1404.4 and IRC Section R703.4.

3.2.16 Finish Coat: Finish coat products are available as Superior Stucco Acrylic and Superior Stucco cement-based. Superior Stucco Acrylic finish coat is an acrylic emulsion binder with aggregate and a proprietary adhesive and is packaged in 5-gallon (19 L) pails. Superior Stucco cement-based finish coat is packaged in multi-layer moisture-resistant 90-pounds bag. Both products can be applied to either the Uniwall or Foam Tite Stucco materials. The total thickness of the base coat and finish coat is limited to 1/2 inch (12.7 mm) for 1-inch by No. 20 gage woven wire and limited in thickness to that specified in IBC Chapter 25 and IRC R703 for 1 1/2-inch by No. 17 gage woven wire.

4.0 INSTALLATION

4.1 General:

The exterior cementitious coating may be applied by hand-troweling or machine-spraying in one or two coats to a minimum 3/8-inch (9.5 mm) thickness, unless noted otherwise. The lath must be embedded in the minimum coating thickness and therefore cannot be exposed. Fasteners for lath must penetrate 1 inch (25.4 mm), minimum, into wood studs. Flashing, corner reinforcement, metal trim and weep screeds must be installed as shown in attached details. See [Figure 1b](#). The coating is applied at ambient temperatures ranging from 40°F to 110°F (4.4°C to 43.3°C) by applicators approved by Stucco Supply Co. of San Jose. The weather-resistive barrier is applied as set forth in Section 3.2.13. An installation card such as noted in [Figure 4](#) must be on the jobsite with the name of the applicator and the product to be used before any weather-resistive barrier or exterior sheathing is installed. Also, see Section 5.6 of this report.

4.2 Application Over Open Framing:

The weather-resistive barrier is placed over open wood studs spaced 24 inches (610 mm) on center, maximum.

The EPS insulation board, XPS, or polyisocyanurate board, as described in Section 3.2.7.1, 3.2.7.2 and 3.2.7.3 is placed horizontally with tongues faced upward, and is temporarily held in place with galvanized staples or roofing nails. Vertical butt joints are staggered a minimum of one stud space from adjacent courses and occur directly over studs.

The lath is applied tightly over the foam plastic insulation board and fastened through the insulation board and water-resistive barrier to wood studs, using No. 11 gage galvanized roofing nails with 3/8-inch-diameter (9.5 mm) heads or No. 16 gage galvanized staples spaced 6 inches (152 mm) on center with a minimum 1-inch (25.4 mm) penetration. Staples must have a minimum crown width of 1/2 inch (12.7 mm). Stapling is permitted only in wood with a specific gravity of 0.5 or greater. Care must be taken to avoid over-driving fasteners. The lath is applied with 1 1/2-inch (38 mm) end laps and sidelaps.

Wall bracing in accordance with 2024 IBC Section 2308.10, 2021, 2018 and 2015 IBC Section 2308.6, 2012 IBC Section 2308.9.3 or 2308.12, IRC Section R602.10 or R602.11, as applicable, or acceptable alternate, is required. Outside wall corners and parapet corners are covered with extra metal corner reinforcement. Weep screeds must comply with, and be installed at the bottom of the wall in accordance with IBC Section 2512.1.2, or 2024, 2021, 2018 and 2015 IRC Section R703.7.2.1, or 2012 IRC Section R703.6.2.1, as applicable. One-and-three-eighths-inch (35 mm), No. 22 gage galvanized steel, J-shaped trim pieces are installed at other areas where insulation board is exposed. At windows and doors, butting J trim metal edges must be caulked. Holes for hose bibbs, electrical panels and other penetrations of substrate surfaces, except those caused by fasteners, must also be caulked. The coating is then applied as described in Section 4.1.

4.3 Application Over Solid Backing:

4.3.1 Fiberboard:

Minimum 1/2-inch-thick (12.7 mm) fiberboard sheathing is installed directly over wood studs, spaced a maximum of 24 inches (610 mm) on center. The fiberboard is temporarily held in place using corrosion-resistant staples or roofing nails. A weather-resistive barrier must be applied over the fiberboard under the conditions set forth in Section 3.2.13 prior to installation of the lath or optional foam board. When the optional insulation boards are used, flat-faced foam plastic boards may be used provided the water-resistive barrier is Tyvek StuccoWrap, as described in Section 3.2.13.1. The lath is attached to studs through the sheathing, with fasteners and spacing as described for insulation board in Section 3.2.7 of this report or as described for fiberboard in 2024 and 2021 IBC Table 2304.10.2, 2018 and 2015 IBC Table 2304.10.1, 2012 IBC Table 2304.9.1, or IRC Table R602.3(1), whichever is more restrictive. Exposed sheathing edges are protected with screeds. Holes in the substrate surface are caulked, and coating is applied as described in Section 4.1.

Wall bracing in accordance with 2024 IBC Section 2308.10, 2021, 2018 and 2015 IBC Section 2308.6, 2012 IBC Section 2308.9.3 or 2308.12, or IRC Section R602.10 or R602.11, as applicable, or an acceptable alternate, must be provided. Weep screeds must comply with, and be installed at the bottom of the wall in accordance with, IBC Section 2512.1.2 or 2024, 2021, 2018 and 2015 IRC Section R703.7.2.1, or 2012 IRC Section R703.6.2.1, as applicable. Galvanized steel, J-shaped trim pieces must be installed at other areas where insulation board is exposed. See [Figure 1](#) for typical installation details. At windows and doors, flashing as described in Section 3.2.13.3 is required. Butting J-trim and approved metal edges, when installed, must be flashed as described in Section 3.2.13.3. Holes for hose bibbs, electrical panels and other penetrations of substrate surfaces, except those caused by fasteners, must also be flashed as described in Section 3.2.14. The coating must then be applied as described in Section 4.1.

4.3.2 Wood Structural Panels:

Wood structural panels are applied directly to wood studs under conditions as set forth in Section 3.2.11 of this report and 2024 IBC Table 2308.10.3(3), 2021, 2018 and 2015 IBC Table 2308.6.3(3), 2012 IBC Table 2308.9.3(3), or IRC Table 602.3(3), as applicable. The water-resistive barrier, optional insulation board, wire fabric lath, and coating must be applied as described in Section 4.3.1 for fiberboard.

4.3.3 Gypsum Sheathing:

Minimum 1/2-inch-thick (12.7 mm), water-resistant core gypsum sheathing is installed directly on wood studs in a manner similar to the installation over fiberboard. Gypsum sheathing must be fastened in accordance with IBC Table 2508.1 or IRC Table R702.3.5, as applicable. The system may also be applied to minimum 0.032-inch-thick (No. 20 gage) (0.813 mm) steel studs spaced at 16 inches (406 mm) on center. System application is similar to that for wood studs, except No. 8, 0.409-inch-head-diameter (10.4 mm), minimum 1³/₁₆-inch-long (30.2 mm), self-tapping screws, spaced at 6 inches (152 mm) on center, secure the sheathing. A weather-resistive barrier is required over the gypsum sheathing prior to installation of the lath and coating as described in Section 3.2.13. Insulation board may be installed over the weather-resistive barrier prior to the installation of lath and coating. Lath is secured with No. 8, 0.409-inch-head-diameter (10.4 mm), minimum 1¹/₄-inch-long (32 mm), self-tapping wafer-head screws spaced 6 inches (152 mm) on center. Screw penetration is 1/4 inch (6.4 mm), minimum, beyond the stud.

4.3.4 Concrete and Masonry:

Surface preparation must be in accordance with IBC Section 2510.7. Surface must be clean, free of dust and other particles, and sufficiently damp to ensure proper bonding. The Uniwall Exterior Wall and Insulation Stucco System is applied directly to the prepared surface at a minimum thickness of 3/8 inch (9.5 mm), in accordance with applicable provisions of Section 4.1.

4.4 One-hour Fire-resistance-rated Exterior Wall Assemblies– rated from the interior face and exterior face:

4.4.1 First Assembly:

4.4.1.1 Interior Face: One layer of 5/8-inch-thick (15.9 mm), Type X gypsum wallboard, water-resistant backerboard or veneer base, complying with ASTM C36 or ASTM C1396, must be applied parallel or at right angles to the interior face of 2-by-4 wood studs spaced 24 inches (610 mm) on center, maximum. The gypsum board must be attached using 6d coated gypsum wallboard nails, 1⁷/₈ inches (48 mm) long, with a 1/4-inch-diameter (6.4 mm) head, at 7 inches on center to studs, plates and blocking. All gypsum wallboard joints must be backed with minimum 2-by-4 wood framing, taped and treated with joint compound in accordance with ASTM C840 or GA216. Fastener heads must be treated with joint compound in accordance with ASTM C840 or GA216.

4.4.1.2 Exterior Face: One layer of minimum $5/8$ -inch-thick (15.9 mm), Type X, water-resistant core, treated gypsum sheathing, 48 inches (1219 mm) wide, is applied parallel to studs with No. 11 gage, galvanized roofing nails, $1\ 3/4$ inches (44.5 mm) long, with $7/16$ - or $1/2$ -inch-diameter (11.1 or 12.7 mm) heads at 4 inches (102 mm) on center at board perimeter and 7 inches (178 mm) on center at intermediate studs. The sheathing is nailed to top and bottom plates at 7 inches (178 mm) on center. A weather-resistive barrier is required over the sheathing. The lath and wall coating are then applied as described in Section 4.2.

4.4.1.3 Axial Design: Axial loads applied to the wall assembly must be limited to the lesser of the following:

1. The wood stud axial design stress for the wall assembly calculated in accordance with Sections 3.6 and 3.7 of ANSI AWC NDS (2024, 2021, 2018, 2015 and 2012 IBC and IRC), is limited to $0.78 F'_c$.
2. The maximum stress must not exceed $0.78 F'_c$ at a maximum slenderness ratio (l_e/d) of 33.

4.4.2 Second Assembly (Limited Load-bearing):

4.4.2.1 Interior Face: One layer of $5/8$ -inch-thick (15.9 mm), Type X gypsum wallboard, water-resistant backerboard or veneer base, complying with ASTM C36 or ASTM C1396, must be applied parallel or at right angles to the interior face of 2-by-4 wood studs or larger (limited load per stud) spaced maximum 24 inches (610 mm) on center. Framing must be installed per code. The gypsum board must be attached using #6 - $1\ 5/8$ -inches long, coarse threaded, bugle head drywall screws, at 8-inches on-center around the perimeter and 12-inches on center in the field of the panel, plates and blocking. Fasteners around the perimeter of the gypsum wallboard were spaced $3/8$ -inch from the edge of the panel. All gypsum wallboard joints must be backed with minimum 2-by-4 wood framing, taped and treated with joint compound in accordance with ASTM C840 or GA216. The stud cavity insulation consisted of $3\ 1/2$ -inches, thick, R13 Kraft faced fiberglass batt insulation. The insulation batts must be secured to the wood studs by stapling the paper facing to the outside edges of the studs using $1/2$ -inch crown staples spaced at minimum, 8-inches on center.

4.4.2.2 Exterior Face: The exterior insulation complying with Sections 3.2.7 and having maximum 2-inches-thickness (50.8 mm) must be attached to the studs in accordance with Section 4.2. Polyisocyanurate insulation boards used in the assembly must be Atlas Roofing EnergyShield® (ESR-1375) with a maximum thickness of 1-inch (24.5 mm). The Uniwall stucco system must then be applied to the lath in accordance with Section 4.1, at a minimum thickness of $3/8$ inch (9.5 mm).

4.4.2.3 Axial Design: Axial loads applied to the wall assembly must be limited to the lesser of the following:

1. 1,420 pounds (6316 N) per stud.
2. A maximum of 60 percent of the load calculated in accordance with Sections 3.6 and 3.7 of ANSI AWC NDS (2024, 2021, 2018, 2015 and 2012 IBC and IRC).
3. Design stress of $0.78 F'_c$ calculated in accordance with Sections 3.6 and 3.7 of ANSI AWC NDS (2024, 2021, 2018, 2015 and 2012 IBC and IRC).
4. Design stress of $0.78 F'_c$ at a maximum slenderness ratio (l_e/d) of 33 calculated in accordance with Sections 3.6 and 3.7 of ANSI AWC NDS (2024, 2021, 2018, 2015 and 2012 IBC and IRC).

4.4.3 Third Assembly (Limited Load-bearing):

4.4.3.1 Interior Face: As described in Section 4.4.2.1.

4.4.3.2 Exterior Face: One layer of wood structural panel complying with Sections 3.2.11 must be attached to the studs in accordance with Section 4.3.2, except that no insulation board must be installed. The Uniwall stucco system must then be applied to the lath in accordance with Section 4.1, at a minimum thickness of $3/8$ inch (9.5 mm).

4.4.3.3 Axial Design: The allowable axial loading for this system is limited as described in Section 4.4.2.3.

4.4.4 Fourth Assembly (Limited Load-bearing):

4.4.4.1 Interior Face: As described in Section 4.4.2.1.

4.4.4.2 Exterior Face: One layer of wood structural panel complying with Section 3.2.11 must be attached to the studs in accordance with Section 4.3, followed by the insulation boards complying with Section 3.2.7 and having maximum 2-inches-thickness (50.8 mm). Polyisocyanurate insulation boards used in the assembly must be Atlas Roofing EnergyShield® (ESR-1375) with a maximum thickness of 1-inch (24.5 mm). The Uniwall stucco system must then be applied to the lath in accordance with Section 4.1, at a minimum thickness of $3/8$ inch (9.5 mm).

4.4.4.3 Axial Design: The allowable axial loading for this system is limited as described in Section 4.4.2.3.

4.4.5 Fifth Assembly (Limited Load-bearing):

4.4.5.1 Interior Face: As described in Section 4.4.2.1.

4.4.5.2 Exterior Face: One layer of gypsum sheathing having a minimum thickness of $1/2$ -inch complying with Section 3.2.9 must be attached to the studs in accordance with Section 4.3, followed by the exterior

insulation complying with Section 3.2.7 and having maximum 2-inches-thickness (50.8 mm). Polyisocyanurate insulation boards used in the assembly must be Atlas Roofing EnergyShield® (ESR-1375) with a maximum thickness of 1-inch (24.5 mm). The Uniwall coating must then be applied to the lath in accordance with Section 4.1, at a minimum thickness of $\frac{3}{8}$ inch (9.5 mm).

4.4.5.3 Axial Design: The allowable axial loading for this system is limited as described in Section 4.4.2.3.

4.5 Type I, II, III and IV (Noncombustible) Construction

4.5.1 Without foam plastic: Uniwall must be applied over gypsum sheathing and steel studs, in accordance with Section 4.3.3, without the foam plastic board. Under the 2024, 2021, 2018 and 2015 IBC, for exterior walls on buildings of Types I, II, III, or IV construction, installation of exterior walls greater than 40 feet (21.19 m) in height above grade must comply with Exception 2 of 2024 IBC Section 1402.6 and 2021 and 2018 IBC Section 1402.5 (2015 IBC Section 1403.5). Under the 2012 IBC, for exterior walls on buildings of Types I, II, III, or IV construction, installation of exterior walls is limited to 40 feet (21.19 m) in height above grade in accordance with 2012 IBC Section 1403.5.

4.5.2 With foam plastic: The Uniwall Stucco system with foam plastic must be installed in accordance with [Table 1](#) based in accordance with NFPA 285 testing. See [Figure 3](#) for details.

4.6 Wind Resistance:

Allowable wind load on the system with wood studs at 24 inches (610 mm) on center is 22 psf (1050 Pa) positive and 28 psf (1340 Pa) negative. Supporting framing must be adequate to resist the required wind load. Allowable wind load on the system with metal studs at 16 inches (406 mm) on center over solid gypsum sheathing substrate is 49 psf (2350 Pa) positive or negative. Support framing must be adequate to resist the required wind load, with a maximum allowable deflection of $\frac{1}{240}$ of the span.

4.7 Miscellaneous:

4.7.1 Inspection Requirements: Building department inspection is required of lath installation prior to application of the coating, as required by the applicable code. The Uniwall System requires inspections, in accordance with IBC Section 110.3.5 and IRC Section R109.1.5.1. A declaration, such as that shown in [Figure 5](#), must be completed and signed in duplicate, for presentation to the building owner and the code official with the plastering contractor's installation card.

4.7.2 Control Joints: Control joints must be installed as specified by the architect, designer or builder, in that order.

4.7.3 Curing: Curing must be in accordance with Superior Stucco application instructions.

4.7.4 Soffits: The system may be applied to soffits, provided the coating is applied over metal lath complying with Section 3.2.8.1 in lieu of wire fabric lath. Metal lath fastening must comply with ASTM C926 or C1063 (IBC), or 2024, 2021, 2018 and 2015 IRC Section R703.7.1, or 2012 IRC Section R703.6.1, as applicable except the fastener length must be increased by the thickness of any substrate.

4.7.5 Sills: The system may be applied to sills at locations such as windows and other similar areas. Sill with depths of 6 inches (152 mm) or less may have the coating and lath applied to any substrate permitted in this report, provided the coating, lath, weather-resistive barrier and substrate are installed in accordance with the appropriate section of this report. Sills with depths exceeding 6 inches (152 mm) must have substrates of solid wood or plywood. The substrate must be fastened in accordance with the applicable code, and a double layer of a complying weather-resistive barrier is applied over the substrate. The coating, lath and optional insulation board are applied in accordance with Section 4.3 of this report.

5.0 CONDITIONS OF USE:

The UNIWALL EXTERIOR WALL AND INSULATION STUCCO SYSTEM described in this report comply with, or are suitable alternatives to what is specified in, those codes listed in Section 1.0 of this report, subject to the following conditions:

- 5.1** The materials and methods of installation must comply with this report and the manufacturer's published instructions. In the event of conflict between the manufacturer's published installation instructions and this report, this report governs.
- 5.2** Installation must be by contractors acceptable to **STUCCO SUPPLY CO. OF SAN JOSE**.
- 5.3** The system is recognized as a one-hour fire-resistance-rated assembly, from the interior face and the exterior face, when installation complies with Section 4.4 of this report.
- 5.4** The interior of the building must be separated from the foam plastic insulation board with a thermal barrier complying with the applicable code, such as $\frac{1}{2}$ -inch (12.7 mm) regular gypsum wallboard mechanically attached in accordance with the code.

- 5.5 A completed installation card, such as that shown in [Figure 4](#), must be left at the jobsite for the owner, and a copy must be filed with the building department.
- 5.6 For the UNIWALL EXTERIOR WALL AND INSULATION STUCCO SYSTEM, inspections are required in accordance with Section 4.7.1. A declaration, such as that shown in [Figure 5](#), must be left with the building owner, and a copy must be filed with the code official.
- 5.7 Foam plastic insulation boards on exterior walls of wood construction must be located at least 6 inches (152 mm) from the ground in areas where hazard of termite damage is very heavy in accordance with 2024, 2021, 2018 and 2015 IBC Section 2603.8 (2012 IBC Section 2306.9) and 2024 IRC Section R305.4 (2018, 2015, and 2012 IRC Section R318.4), as applicable.

6.0 EVIDENCE SUBMITTED

- 6.1 Data in accordance with the [ICC-ES Acceptance Criteria for Cementitious Exterior Wall Coatings \(AC11\)](#), dated January 2013 (editorially revised October 2024).
- 6.2 Data in accordance with ASTM E119, ASTM E136, ASTM E2707 and NFPA 285.
- 6.3 Documentation of an ICC approved quality control system for the manufacture of products recognized in this report.

7.0 IDENTIFICATION

- 7.1 The ICC-ES mark of conformity, electronic labeling, or the evaluation report number (ICC-ES ESR-5231) along with the name, registered trademark, or registered logo of the report holder must be included in the product label.
- 7.2 In addition, the factory-prepared mixes are delivered to the jobsite in water-resistant bags with labels bearing the manufacturer’s address; identification of the components; weight of the packaged mix; storage instructions; maximum amount of water and other components that may be added and conditions that must be considered in determining actual amounts; curing instructions; and the insulation boards are identified in accordance with their respective ICC-ES evaluation reports and board densities.
- 7.3 Foam plastic insulation boards must be identified in accordance with their respective ICC-ES evaluation reports.
- 7.4 Fome-Cor® Board must be identified in accordance with evaluation report [ESR-1614](#).
- 7.5 The report holder’s contact information is the following:

STUCCO SUPPLY CO. OF SAN JOSE
1601 LITTLE ORCHARD STREET, SUITE E
SAN JOSE, CALIFORNIA 95110
(408) 292-0454
www.stuccosupplyco.com

TABLE 1 – NONCOMBUSTIBLE CONSTRUCTION – COMPONENTS OF CONSTRUCTION

ITEM NO.	WALL COMPONENTS	MATERIALS
1	Base Wall System – Use either A, B, C or D	A – Steel Studs (minimum 3 5/8-inch deep, minimum 20-gauge (37.5 mils), spaced maximum 24 inches on center, laterally braced every 4 feet vertically), with (1) layer of nominal 5/8-inch thick Type X gypsum wallboard on the interior side of the stud wall. B – FRT Wood Stud (minimum 2x4, spaced maximum 24 inches on center, laterally braced every 4 feet vertically), with (1) layer of nominal 5/8-inch thick Type X gypsum wallboard on the interior side of the stud wall. C – Cast Concrete Walls (2-inch thickness min.) D – CMU Concrete Walls (4-inch thickness min.)
	Floorline Firestopping (Not Shown) Use A if 1A System	A – Non-combustible mineral wool safing (minimum density of 4.0 lbs./ft ³) in each stud cavity and at each floorline. Mineral wool to be attached with z-clips or friction-fit into each stud cavity. B – Fire retardant treated (FRT) lumber (minimum 1½-inch thick). ¹

	Use B if 1B System	
	Base Wall Cavity Insulation ² (Not Shown) – Use either A, B, C or D	A – None B – Non-combustible insulation complying with ASTM E136. C – Mineral-fiber (faced or unfaced) complying with applicable code. D – Fiberglass batt insulation, Class A (faced or unfaced) complying with applicable code.
2	Exterior Sheathing –	A – ½-inch thick exterior gypsum sheathing. B – ½ -inch min. FRT exterior gypsum sheathing. C – ½ -inch min. FRT plywood sheathing.
3	Water-Resistive Barrier (WRB) – Note: WRB must be applied over the exterior sheathing for base wall systems A and B.	A – Henry® Super Jumbo Tex® (ESR-1027) (60-minute Grade D asphalt-saturated kraft building paper)
4	Exterior Insulation	A – Any Type II EPS – maximum 2-inches with equal or less potential heat value of 2250 Btu/ft ² . B – Type IV XPS – maximum 2-inches with equal or less potential heat value of 2250 Btu/ft ² . C – EnergyShield® (ESR-1375) Polyisocyanurate foam sheathing – maximum 1-inch.
5	Exterior Cladding –	A – Uniwall Exterior Stucco System (minimum 3/8-inch thickness)
6	Lath	A – 20-gauge woven wire lath. B – Welded/expanded metal lath conforming to ASTM C847.
7	Window Detail (Not Shown) –	25 gage (minimum) steel 2 ½ -inches wide casing bead encapsulating the foam board (when exterior insulation is used, width dependent upon insulation thickness), with minimum 0.04-inch aluminum flashing

For SI: 1 inch= 25.4 mm, 1 foot = 304.8 mm, 1 pcf = 16.01 kg/m³

¹Fire retardant treated (FRT) lumber must comply with IBC Section 2303.2.

²Insulation must comply with the applicable requirements of IBC Section 720.2.

TABLE 2 - PROPERTIES EVALUATED

Properties	2024 and 2021 International Building Code	2024 and 2021 International Residential Code
Wind Resistance	Section 1609	Section R301.2.1
Installation	Section 2512	Section R703.7
Fire-Resistance-Rated Construction	Section 703.2	Section R302
Weather Protection	Section 1402.2 Section 2512	Section R703.2 Section R703.7.3
Exterior Walls of Types I, II, III and IV Construction	Section 2603.5	Not Applicable

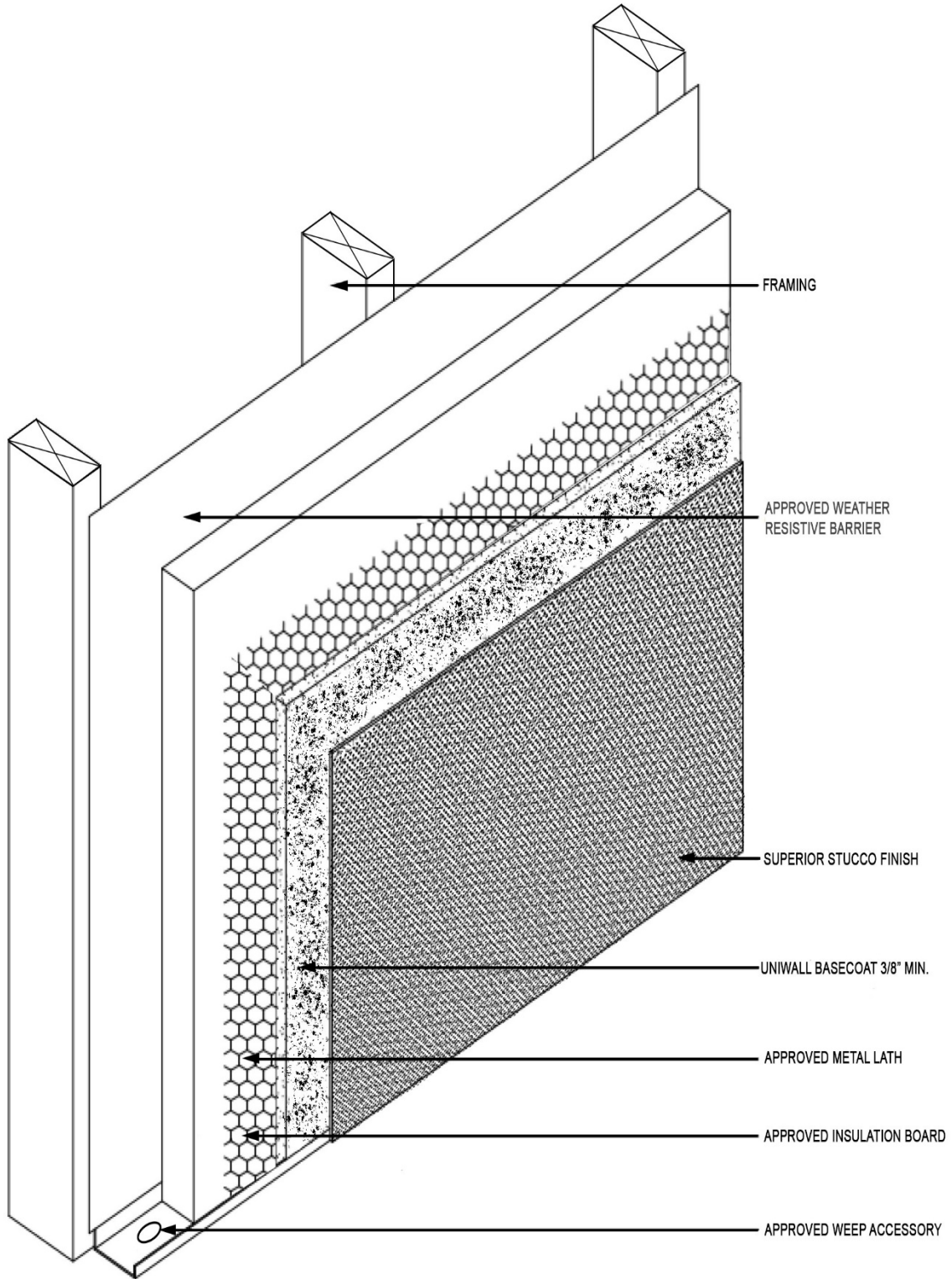

FIGURE 1a – TYPICAL WALL CONSTRUCTION

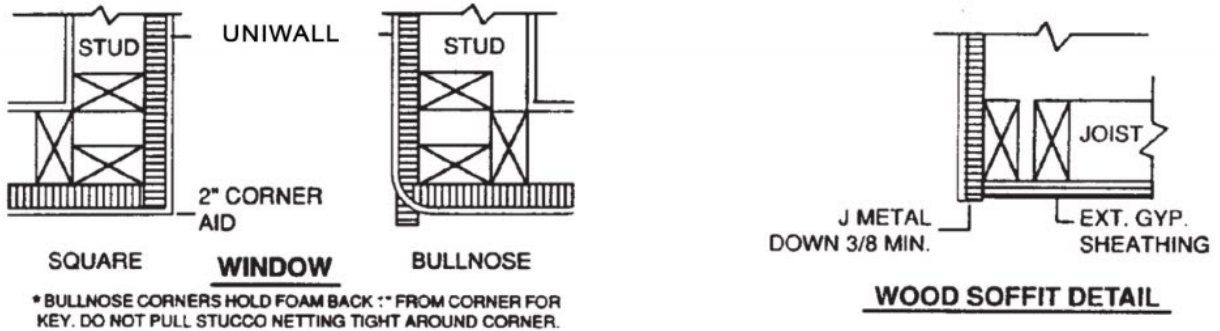
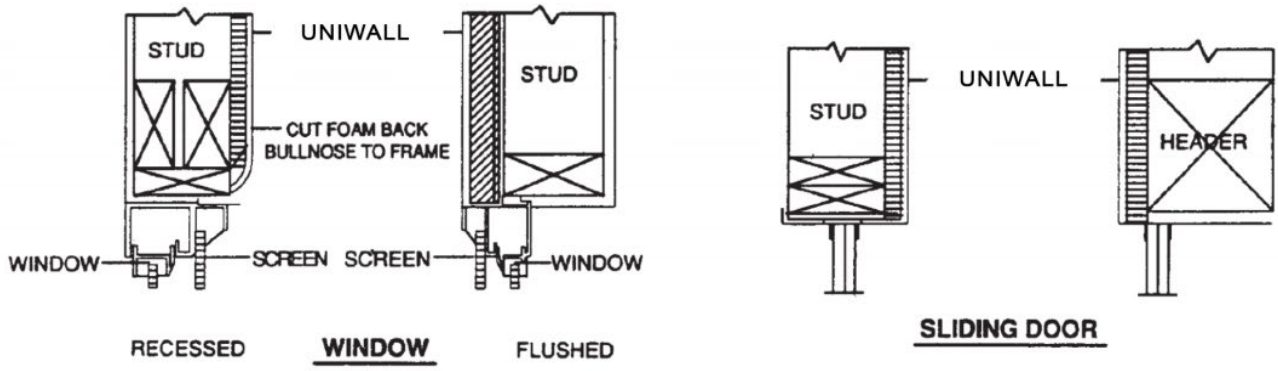
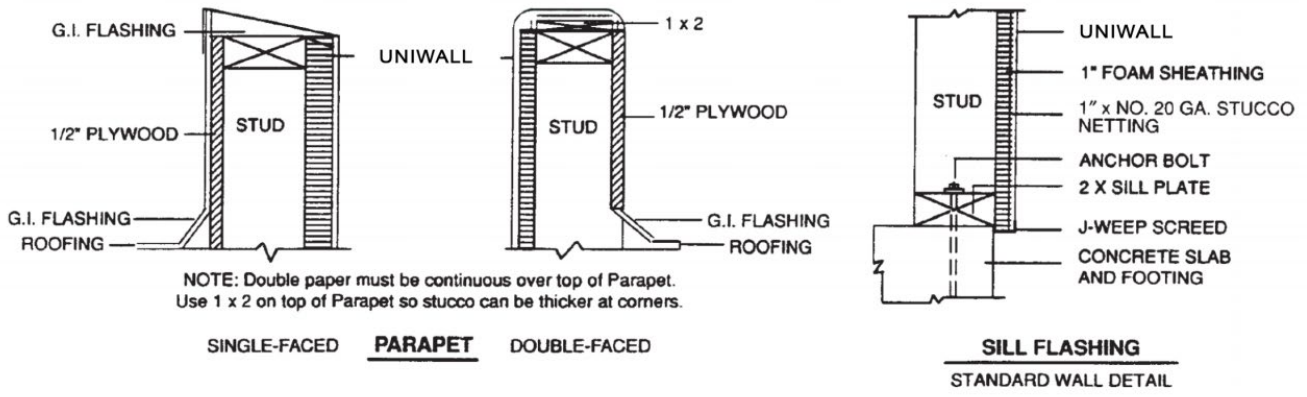
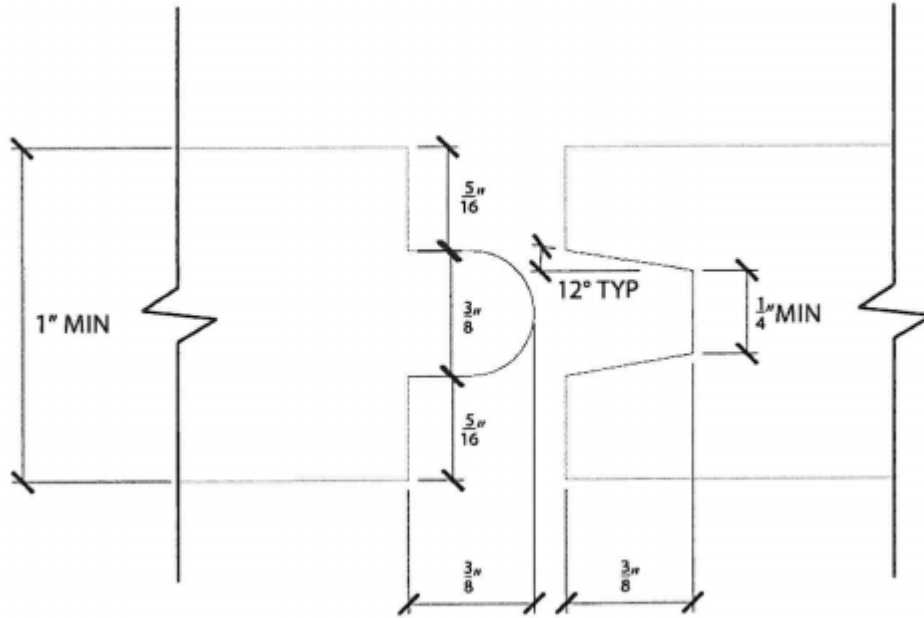

FIGURE 1b – TYPICAL WALL CONSTRUCTION



- Tongue and Groove Detail for Insulation Boards

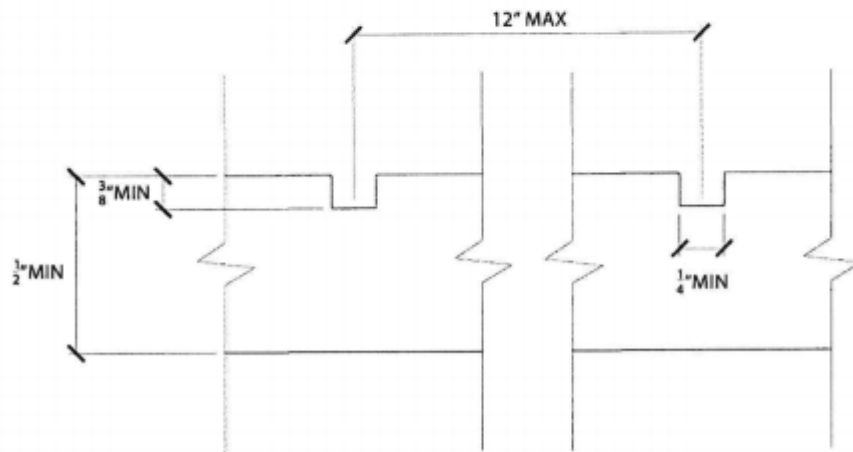
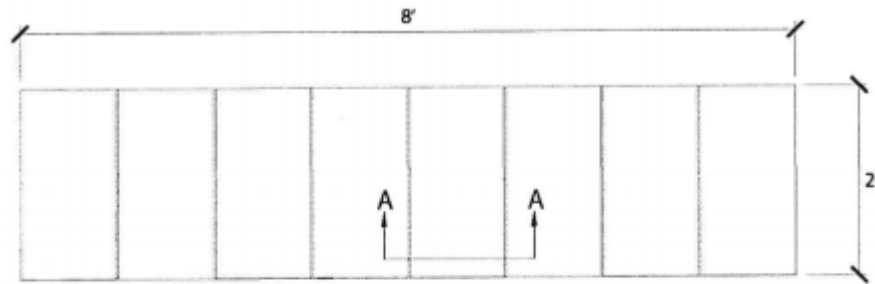

FIGURE 2- TYPICAL TONGUE AND GROOVE DETAILS FOR INSULATION BOARDS

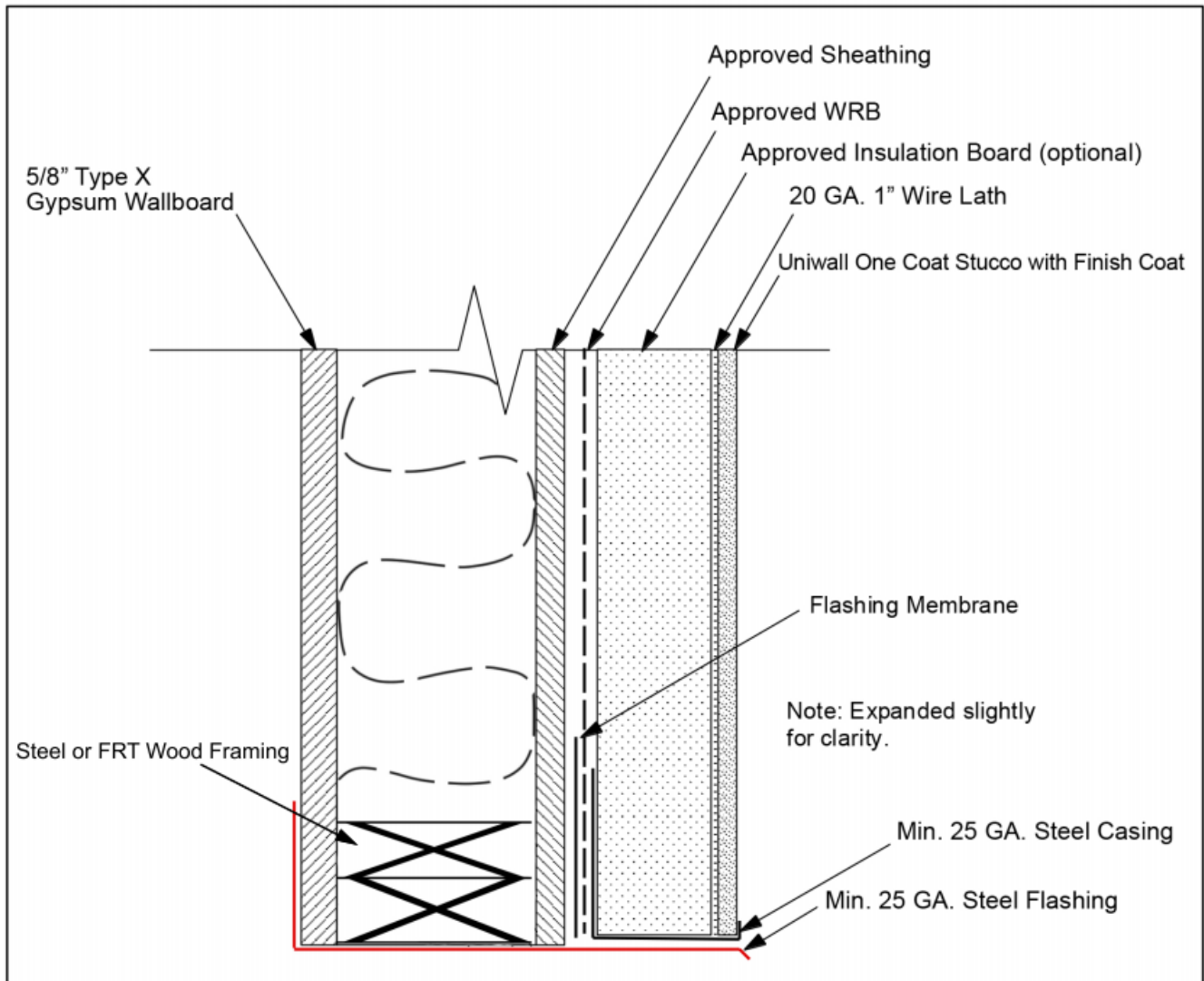

FIGURE 3 – TYPICAL HEAD OF WINDOW OPENING CONSTRUCTION FOR NFPA 285 COMPLYING WALL (SEE TABLE 1 FOR DETAILS)

INSTALLATION CARD

UNIWALL EXTERIOR WALL AND INSULATION STUCCO SYSTEM STUCCO SUPPLY CO OF SAN JOSE

Job Address

Evaluation Report ER-_____

Date of Job Completion _____

Plastering Contractor

Name: _____

Address: _____

Telephone No. () _____

Approved Contractor as issued

By the coating manufacturer: _____

This is to certify that the exterior coating system on the building exterior at the above address has been installed in accordance with the evaluation report specified above and the manufacturer's instructions.

Signature of authorized representative
of plastering contractor

Date

This installation card must be presented to the building inspector after completion of work and before final inspections.

FIGURE 4 – INSTALLATION CARD

DECLARATION

UNIWALL EXTERIOR WALL AND INSULATION STUCCO SYSTEM STUCCO SUPPLY CO OF SAN JOSE

Project Address: _____ Date: _____

The field batching and mixing of all components of the exterior wall coating at the address noted above have been continuously inspected. The field batching and mixing have been found to comply with current Evaluation Report ER- _____ and approved plans.

AUTHORIZED INSPECTOR'S SIGNATURE _____

AUTHORIZED INSPECTOR'S NAME (PRINT) _____

EMPLOYER'S NAME _____

EMPLOYER'S ADDRESS _____

_____ TELEPHONE NO. _____

THIS IS TO CERTIFY THAT THE ABOVE-NOTED INSPECTOR, APPROVED BY STUCCO SUPPLY CO OF SAN JOSE, WAS AUTHORIZED TO INSPECT THE PROJECT SO NOTED AND WAS TRAINED TO PROPERLY DISCHARGE HIS DUTIES.

SIGNATURE OF EMPLOYEE OR OFFICER OF REPORT HOLDER

SIGNER'S NAME (PRINT)

DATE

*Signature required only if inspector is not an employee of evaluation report holder.

FIGURE 5 – DECLARATION CARD

ICC-ES Evaluation Report ESR-5231 CA Supplement w/ DSA and OSHPD

Reissued March 2026

This report is subject to renewal March 2027.

www.icc-es.org | (800) 423-6587 | (562) 699-0543 A Subsidiary of the International Code Council®

DIVISION: 09 00 00—FINISHES

Section: 09 24 00—Portland Cement Plastering

REPORT HOLDER:

STUCCO SUPPLY CO. OF SAN JOSE

EVALUATION SUBJECT:

UNIWALL EXTERIOR WALL AND INSULATION STUCCO SYSTEM

1.0 REPORT PURPOSE AND SCOPE

Purpose:

The purpose of this evaluation report supplement is to indicate that Uniwall Exterior Wall and Insulation Stucco System, described in ICC-ES evaluation report [ESR-5231](#), have also been evaluated for compliance with the codes noted below.

Applicable code edition(s):

- 2022 California Building Code (CBC)

For evaluation of applicable Chapters adopted by the [California Office of Statewide Health Planning and Development \(OSHPD\) AKA: California Department of Health Care Access and Information \(HCAI\) and the Division of State Architects \(DSA\)](#), see Sections 2.1.1 and 2.1.2 below.

- 2022 California Residential Code (CRC)

2.0 CONCLUSIONS

2.1 CBC:

The Uniwall Exterior Wall and Insulation Stucco System, described in Sections 2.0 through 7.0 of the evaluation report [ESR-5231](#), comply with CBC Chapters 25 and 26, provided the design and installation are in accordance with the 2021 *International Building Code*® (IBC) provisions noted in the evaluation report and the additional requirements of CBC Chapters 25 and 26, as applicable.

The Uniwall Exterior Wall and Insulation Stucco System may be used in the exterior design and construction of exterior wall assemblies in new buildings located in a Fire Hazard Severity Zone within State Responsibility Areas or any Wildland-Urban Interface Area, provided installation is in accordance with the 2021 *International Building Code*® (IBC) provisions noted in the evaluation report and the additional requirements of Sections 701A.3 and 707A.4 of the CBC. The Uniwall Exterior Wall and Insulation Stucco System, when constructed with foam plastic insulation boards as described in Section 4.3 of [ESR-5231](#), complies with the performance requirements of CBC Section 707A.4 when tested in accordance with ASTM E2707 and Item 3 of CBC Section 707A.4. The Uniwall Exterior Wall and Insulation Stucco System, when constructed with foam plastic insulation boards as described in Section 4.4 of [ESR-5231](#), complies with the performance requirements of CBC Section 707A.4 when tested in accordance with ASTM E119 and Item 5 of CBC Section 707A.4.

2.1.1 OSHPD:

The Uniwall Exterior Wall and Insulation Stucco System, described in Sections 2.0 and 7.0 of the evaluation report [ESR-5231](#), complies with CBC amended Chapters 25 and 26, provided the design and installation are in accordance with the 2021 *International Building Code*® (IBC) provisions noted in the evaluation report and the additional requirements in CBC Chapters 25 and 26, as applicable.

2.1.2 DSA:

The Uniwall Exterior Wall and Insulation Stucco System, described in Sections 2.0 and 7.0 of the evaluation report [ESR-5231](#), complies with CBC amended Chapters 25 and 26, provided the design and installation are in accordance with the 2021 *International Building Code*® (IBC) provisions noted in the evaluation report and the additional requirements in CBC Chapters 25 and 26, as applicable.

2.2 CRC:

The Uniwall Exterior Wall and Insulation Stucco System, described in Sections 2.0 through 7.0 of the evaluation report [ESR-5231](#), complies with CRC Chapters 3 and 7, provided the design and installation are in accordance with the 2021 *International Residential Code*® (IRC) provisions noted in the evaluation report and the additional requirements of CRC Chapter 3 and 7, as applicable.

The Uniwall Exterior Wall and Insulation Stucco System may be used in the exterior design and construction of exterior wall assemblies in new buildings located in a Fire Hazard Severity Zone within State Responsibility Areas or any Wildland-Urban Interface Area, provided installation is in accordance with the 2021 *International Residential Code*® (IRC) provisions noted in the evaluation report and the additional requirements of Sections R337.1.3 and R337.7.4 of the CRC. The Uniwall Exterior Wall and Insulation Stucco System, when constructed with foam plastic insulation boards as described in Section 4.3 of [ESR-5231](#), complies with the performance requirements of CRC Section R337.7.4 when tested in accordance with ASTM E2707 and Item 3 of CRC Section R337.7.4. The Uniwall Exterior Wall and Insulation Stucco System, when constructed with foam plastic insulation boards as described in Section 4.4 of [ESR-5231](#), complies with the performance requirements of CRC Section R337.7.4 when tested in accordance with ASTM E119 and Item 5 of CRC Section R337.7.4.

This supplement expires concurrently with the evaluation report, reissued March 2026.